

MINI-PLASI

Pulse Light Approach Slope Indicator

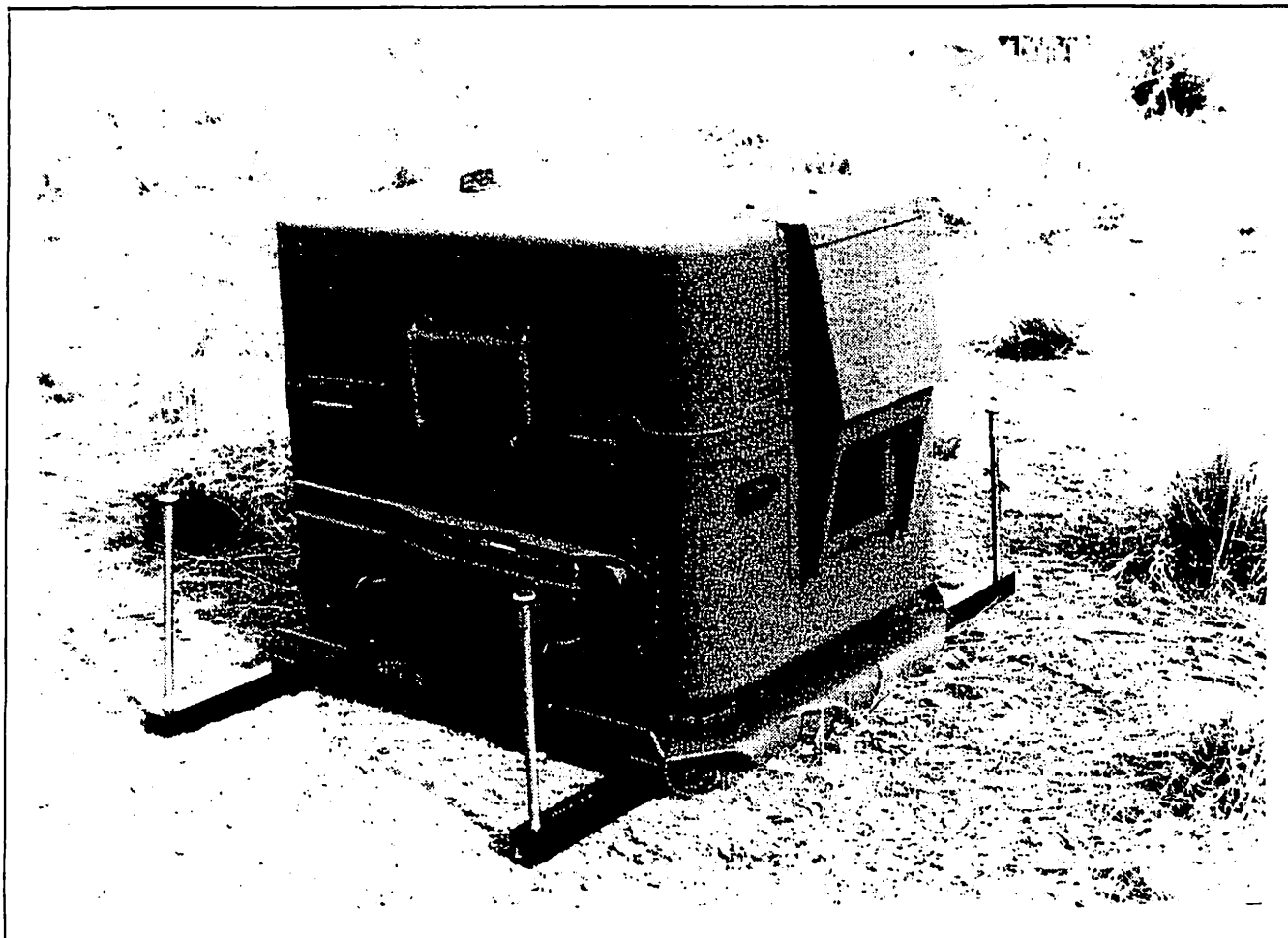

SERVICE & MAINTENANCE MANUAL

Manual Number PLF051 6 May 2003

**APPLICABLE TO
DA3401 (28 VDC), DA3501 (120 VAC)
MINI-PLASI**



DEVORE AVIATION CORPORATION
ALBUQUERQUE, NEW MEXICO, USA OF AMERICA

SECTION I - INTRODUCTION

1.0 Purpose 3

SECTION II - RECOMMENDED SERVICING SCHEDULE

2.0 Routine Service 4
2.1 Servicing 4

SECTION III - MINI-PLASI MAINTENANCE

3.0 Routine Maintenance: 7
3.0.1 Relamping: 7
3.0.2 Drive Chain Tensioning: 7
3.0.3 Shutter Chain Tension: 7
3.1 Component Removal and Installation: 8
3.1.1 Pulse Generator: 8
3.1.2 Shutter Motor: 8
3.1.3 Drive Chain and Shutter Chain 8
3.1.4 Filter Removal: 9
3.1.5 Cooling Fan: 9

SECTION IV - TROUBLE ANALYSIS CHART 10

FIGURES

Figure 1 28 VDC MINI-PLASI Wiring Diagram 11
Figure 2 120 VAC MINI-PLASI Wiring Diagram 12



MINI-PLASI Pulse Light Approach Slope Indicator

SERVICE & MAINTENANCE MANUAL

SECTION I - INTRODUCTION

1.0 Purpose

This Manual provides the information required for service of the MINI-PLASI Pulse Light Approach Slope Indicator.

The MINI-PLASI will require a minimum of servicing. It is enclosed in a weather tight housing and is designed for continuous unattended operation. With proper installation and adherence to the recommended servicing schedule presented in **Section II**, the System is designed to deliver trouble-free operation. The System may be maintained readily by technician level personnel.

The program outlined in **Section II** provides a recommended servicing schedule based on continuous System usage. The user should consider the schedule as a guide, and based on local environmental conditions and service experience, may find it expedient to either increase or decrease the frequency of some of the listed service actions.

For operating and installation instructions refer to the Operation & Installation Manual PLG051 and the appropriate Illustrated Parts Manual:
PLA051 (120 VAC) or PLA053 (28 VDC) for fixed wing signal
PLA052 (120 VAC) or PLA054 (28 VDC) for helicopter signal



SECTION II - RECOMMENDED SERVICING SCHEDULE

2.0 Routine Service

1. Remove incoming line power before performing service unless noted otherwise.

2.1 Servicing

<u>Item</u>	<u>Service Frequency</u>	<u>Service Action</u>
Front window- outside.	At Lamp change if required.	1. Clean with optical cleaning solution (Kodak lens cleaning fluid or equivalent) using a lint free cloth or tissue.
Condenser lens, objective lens, red filter and inside of window	At lamp change, if required	1. Clean with optical cleaning solution (Kodak lens cleaning fluid or equivalent) using a lint free cloth or tissue.
Lamp	As required	<ol style="list-style-type: none"> 1. Remove failed lamp by raising the socket wire lever arm. This will pop the lamp out of the socket. 2. To insert a new lamp, slip lamp contacts into socket slot until the lamp snaps in place. 3. If spare lamp has been used, replace.



<u>Item</u>	<u>Service Frequency</u>	<u>Service Action</u>
Filter	Every 6 months or as required	<ol style="list-style-type: none"> 1. Inspect Filter. The Filter is washable/ reusable; if it is dirty, clean as follows: 2. Remove Filter. 3. Lightly tap off surface dust 4. Clean in a solution of warm water and mild soap detergent. 5. Rinse the Filter from the inside out. Shake and allow to air dry. Do not use air hose. 6. Re-oil Filter element with a light weight filter oil, (light weight motor oil may be used). Re-install Filter.
Drive Chain	Every 6 months	<ol style="list-style-type: none"> 1. Lubricate chains and sprocket teeth with Teflon fortified lubricant (SAE 50 weight non-detergent motor oil may be used if Teflon is not available). Use sparingly. Apply lubricant only to chain and sprocket teeth. 2. Check tightness of all sprocket set screws (6 places). 3. Check chain tension. Turn power on. With chain running, chain sag should be approximately three-eighth inch. If necessary, adjust tension per <i>Paragraph. 3.0.2</i>



<u>Item</u>	<u>Service Frequency</u>	<u>Service Action</u>
Shutter Chains.	Every 6 months	<ol style="list-style-type: none"> 1. Lubricate chains and sprocket teeth with Teflon fortified lubricant (SAE 50 weight non-detergent motor oil may be used if Teflon is not available). Use sparingly. Apply lubricant only to chain and sprocket teeth. Lubricant must not contaminate the Red Filter or Condenser Lens. 2. Check tightness of all sprocket set screws (8 places). 3. Check chain tension for upper and lower chains. Turn power on. With chain running, chain sag should be approximately one-eighth inch (1/8) to one-quarter (1/4) inch. If necessary, adjust tension per Paragraph. 3.0.3
Fan	Every 6 months	<ol style="list-style-type: none"> 1. With power on, check that cooling fan is running normally.



SECTION III - MINI-PLASI MAINTENANCE

3.0 Routine Maintenance:

1. TURN OFF power before performing maintenance unless noted otherwise.

3.0.1 Relamping:

No Tools Required

1. Remove lamp from socket by raising the socket wire lever arm. This will pop the lamp out of the socket.
2. To insert new lamp, slip the lamp contacts into the socket slot until the lamp snaps into place.

3.0.2 Drive Chain Tensioning: - Tools Required - 3/4" wrenches

NOTE: Drive chain tension is correct when the top strand of the moving chain can be deflected approximately 3/8 inch with a firm touch of a finger.

1. Adjust the chain tension with a half inch (1/2) bolt through the idler sprocket.

3.0.3 Shutter Chain Tension: - Tools Required - 7/16" wrenches

NOTE: Tension is correct when the moving chain can be deflected approximately one eighth (1/8) inch: with a firm touch of a finger.

Upper Chain - Tools Required - 7/16" wrenches; straightedge

1. Loosen slightly the two upper bolts securing the bearing block assembly to the pulse generator housing. (Bearing blocks are located nearest to the latch side of the housing).
2. Move the support assembly to tension chain. Tighten bolts.
3. Check the top sprocket alignment by placing a straight edge across both sprocket faces. Adjust if required.

Lower Chain - Tools Required - 7/16" wrenches; straightedge

1. Lower chain tensioning is accomplished in a similar manner using the bolts at the lower end of the bearing supports.



3.1 Component Removal and Installation:

3.1.1 Pulse Generator: - Tools Required - 3/8" socket, ratchet, 6" extension

Removal:

1. Disconnect electrical connector for the lamp.
2. Disconnect electrical connector for the chain drive motor.
3. Disconnect electrical connector for the work light.
4. Remove the four (4) attach bolts securing the pulse generator to the housing floor.
5. Remove the pulse generator.

Installation:

1. Install the pulse generator in reverse order of removal.

3.1.2 Shutter Motor: - Tools Required - 3/8" wrench; 1/8" allen wrench; 3/4" wrenches

Removal:

1. Loosen the drive chain idler sprocket and slip the chain off the drive motor sprocket.
2. Remove the drive motor sprocket from the motor shaft by loosening the set screws.
3. Disconnect the electrical connector for the motor.
4. Remove the four (4) bolts attaching the motor to the pulse generator bracket.
5. Remove motor.

Installation:

1. Install the shutter motor in reverse order of removal.
2. Tension drive chain per Paragraph 3.0.2.

3.1.3 Drive Chain and Shutter Chain: - Tools Required - Needlenose Pliers

Removal:

1. Remove the spring clip and connector plate from the chain master link. (There is only one master link in each chain which is removable).
2. Remove master link.
3. Remove chain from the sprocket.

Installation:

1. Install the chain in reverse order of removal.
2. Check chain tensioning per Paragraph 3.0.2 or 3.0.3.



3.1.4 Filter Removal: - Tools Required - None

Removal

1. Remove four (4) thumb screws securing filter cover.
2. Remove filter.

Installation

1. Install new filter P/N DA1426-1. Install filter cover. NOTE: Cover can only be installed in one position which allows proper positioning of cover ducting for correct airflow. (Screw holes are staggered).

3.1.5 Cooling Fan: - Tools Required - 7/64" allen wrench

Removal

1. Remove the two (2) clips on the electrical connectors from the fan electrical terminals.
2. Remove the four (4) allen head screws securing the fan to the housing.
3. Remove the fan.

Installation

1. Install and secure the fan to the housing using the four (4) allen head screws.
2. Reconnect the electrical leads to the fan electrical terminals. NOTE: If fan does not run on application of electrical power, reverse the electrical connections. Fan will only run when correct polarity is observed.



SECTION IV - TROUBLE ANALYSIS CHART

<u>Malfunction</u>	<u>Probable Cause</u>	<u>Action</u>
Unit will not start, or inadvertent shutdown.	<ol style="list-style-type: none"> 1. No power available to unit. 2. Main power switch/circuit breaker defective. 3. Circuit malfunction. 	<ol style="list-style-type: none"> 1. Check power source. 2. Test switch. Replace if necessary. 3. Troubleshoot circuit. (See figure 1)
Lamp Inoperative.	<ol style="list-style-type: none"> 1. Lamp burned out/ defective. 2. 180 degree F thermostat switch tripped open. 	<ol style="list-style-type: none"> 1. Replace lamp. 2. Correct cause of overheat condition. Reset thermostat switch by resetting red button
Loss of signal.	<ol style="list-style-type: none"> 1. Loss of power. 2. Lamp inoperative. 3. Pulse generator chain drive inoperative. 4. Signal output blocked. 	<ol style="list-style-type: none"> 1. Check power supply. 2. Replace failed lamp. 3. See malfunction listing for pulse generator chain drive system inoperative. 4.a. Check optics for cleanliness. b. Check front window for blockage.
Pulse generator chain drive system inoperative.	<ol style="list-style-type: none"> 1. Shutter motor inoperative. 2. Chain sprocket slippage. 3. Drive or shutter chain slipping or broken. 	<ol style="list-style-type: none"> 1.a. Check motor circuit per wiring diagram. b. If electrical circuit good, replace shutter motor. 2.a. Check tightness of all sprocket set screws. 3.a. Check chain tension. Readjust if necessary. b. Replace chain if broken.
Lamp night dimming system inoperative.	<ol style="list-style-type: none"> 1. Dim/bright selector switch defective. 2. Dimming resistor or stepdown transformer defective. 	<ol style="list-style-type: none"> 1. Replace switch. 2. Replace resistor or transformer.



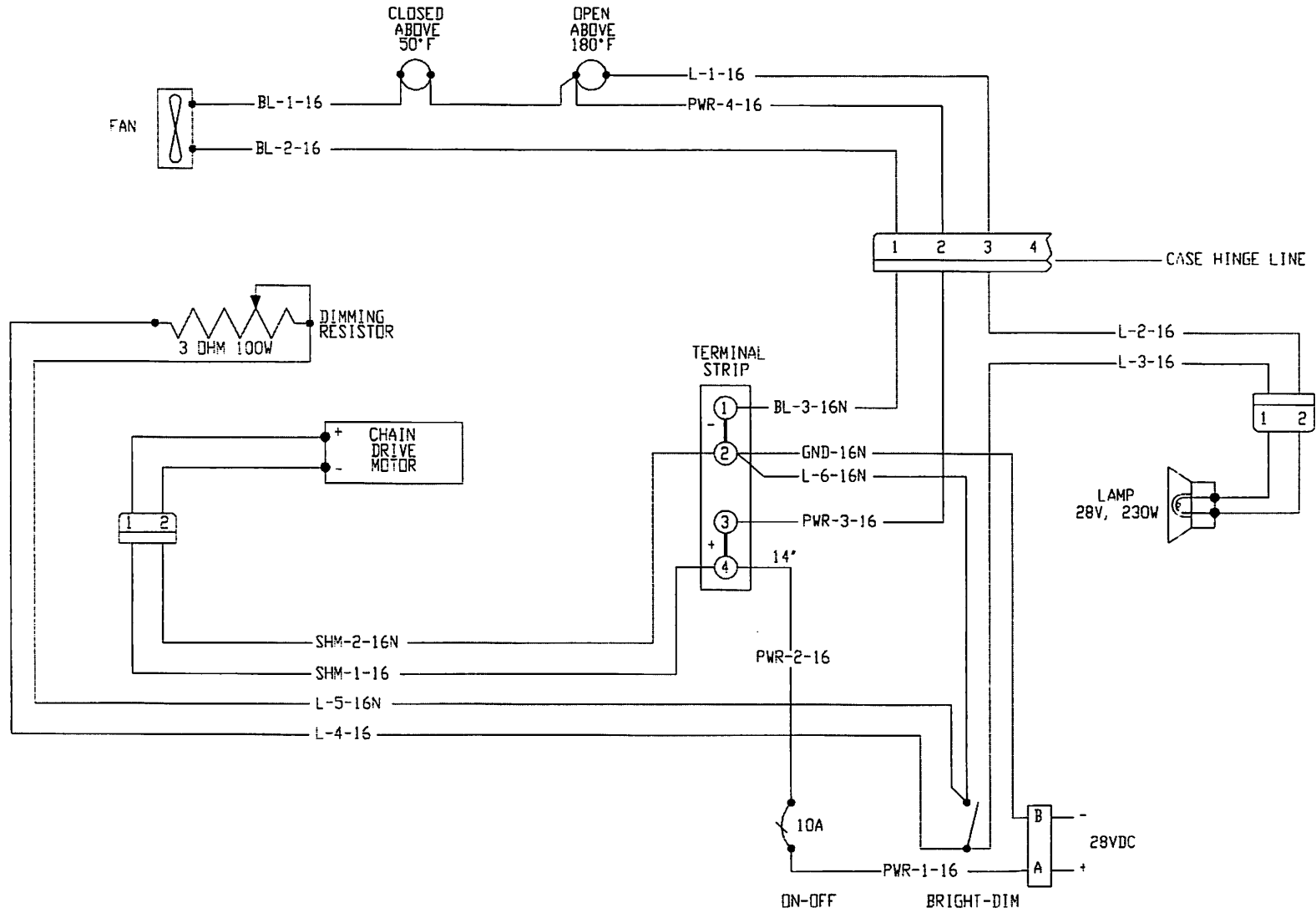

Figure 1 28 VDC MINI-PLASI Wiring Diagram

